

accessori / accessories / accessoires / zubehoer / accessorios

per / for /
pour / für / por
salinero, dalton

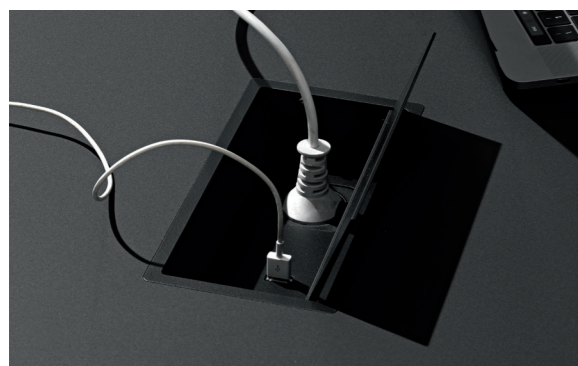
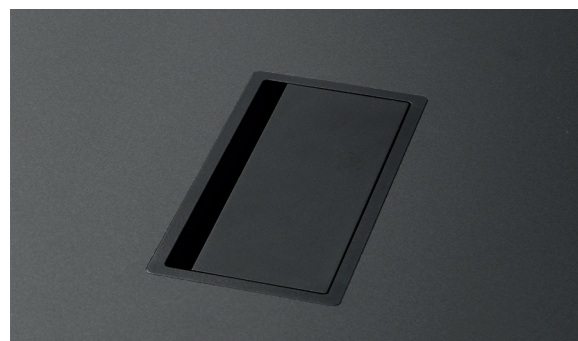

A

- > Dispositivo di alimentazione. Presa elettrica e USB.
- > Power supply device. Electric socket and USB.
- > Système d'alimentation. Prise électrique et USB.
- > Integrierte Steckdose/Usb. Dispositivo de suministro de energía. Toma de corriente y USB.

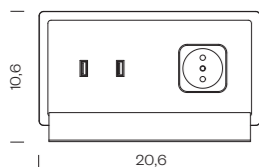

B

- > Dispositivo di ricarica wireless a scomparsa per smartphone dotati di ricevitore Qi o con opportuno adattatore o cover o pellicola per batteria.
- > Retractable wireless charging device for smartphones equipped with Qi wireless receiver or with appropriate adapter or cover or film for battery.
- > Chargeur rétractable sans fil pour mobiles multifonction équipés d'un récepteur Qi ou avec un adaptateur ou un cache approprié ou un film pour batterie.
- > Integriertes, drahtloses Ladegerät für Smartphones, die mit einem Qi-Empfänger, einem geeigneten Adapter oder einer entsprechenden Abdeckung oder Folie für den Akku ausgestattet sind.
- > Dispositivo de carga sin hilos retráctil para teléfonos inteligentes equipados con receptor Qi ó con el adaptador ó cubierta ó película adecuados para la batería.



C

- > Asola su piano con canalina raccolta cavi.
- > Buttonhole on top with cable collection channel.
- > Boucle sur plateau avec gouttière pour câble.
- > Kabelauslass Tischplatte. Ojal sobre mesa con guía para contener cables.

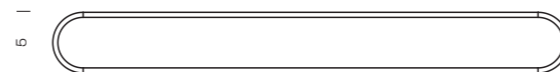

D

- > Vertebra passacavi scrivania/pavimento.
- > Cable guide for desk/floor.
- > Goulotte passe-câbles bureau/sol.
- > Kabelspirale/Kanal. Guía pasacables escritorio/suelo.

**Accessori / Accessories /
Accessoires / Zubehoer /
Accessorios**

- > I tavoli Salinero e Dalton possono essere accessoriati nel seguente modo:
- > The Salinero and Dalton tables can be equipped as follows:
- > Les tables Salinero et Dalton peuvent être équipés comme suit:
- > Die Tische Salinero und Dalton können die folgenden Zubehöre haben:
- > Las mesas Salinero y Dalton se pueden equipar según las combinaciones a continuación:

A (+D)

B (+D)

C (+D)

AB (+D)

BC (+D)

- > L'accessorio D può essere inserito in ogni combinazione, gli accessori A e C non sono tra loro compatibili.
- > The accessory D can be inserted in any combination. Accessories A and C are not compatible with each other.
- > L'accessoire D peut être inséré dans toutes les combinaisons, les accessoires A et C ne sont pas compatibles.
- > Das Zubehör D kann in jeder Kombination eingesetzt werden, die Zubehörteile A und C sind nicht miteinander kompatibel.
- > El accesorio D se puede insertar en todas las combinaciones, los accesorios A y C no son compatibles entre si.

Salinero

Combinazioni disponibili / Available combinations /
Disponibles / Combinaisons disponibles /
Verfügbare Kombination / Combinaciones disponibles

1001 AB

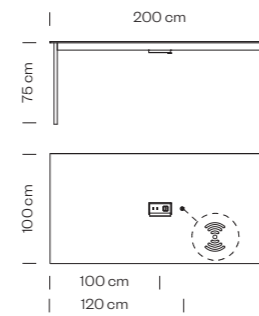

1001 BC

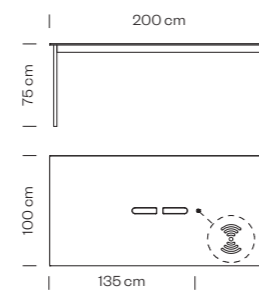

1002 AB

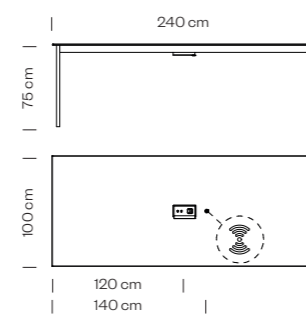

1002 BC

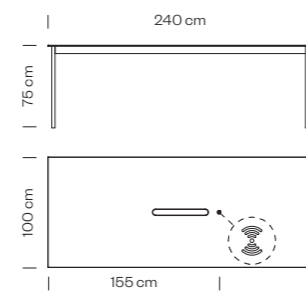

1003 AB

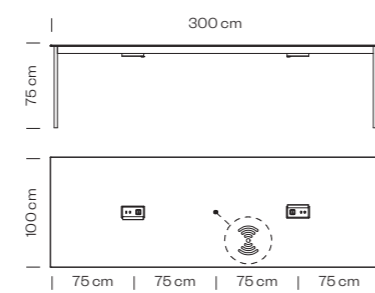

1003 BC

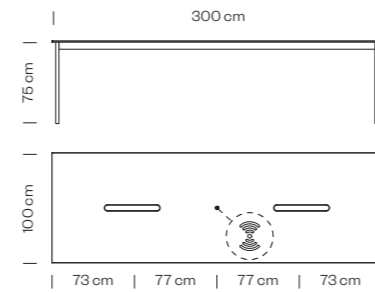

1004 AB

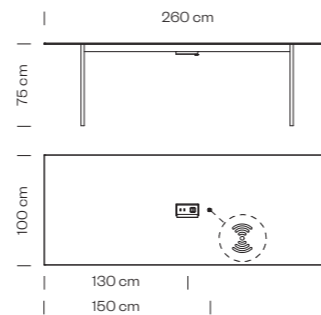

1004 BC

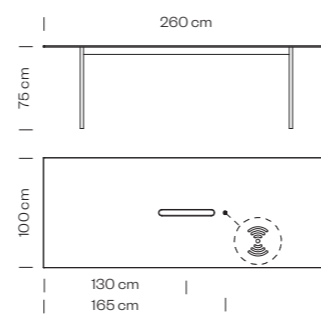

1005 AB

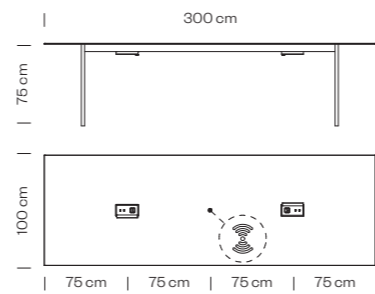

1005 BC

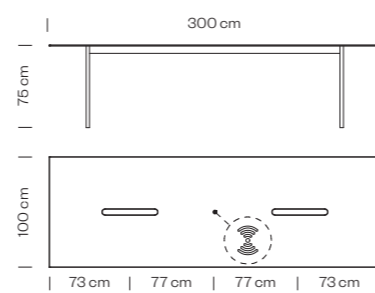

Dalton

Combinazioni disponibili / Available combinations /
Disponibles / Combinaisons disponibles /
Verfügbare Kombination / Combinaciones disponibles

615 AB

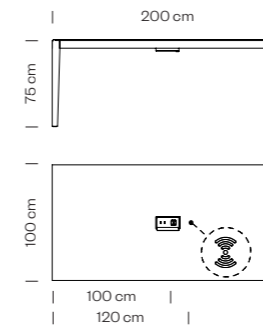

616 AB

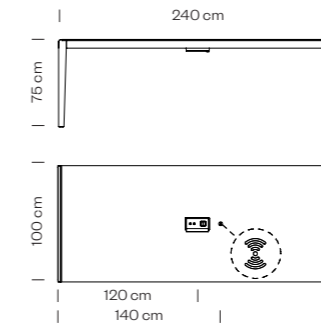

616 BC

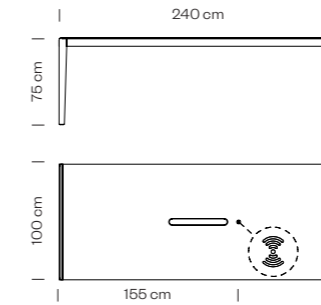

615 BC

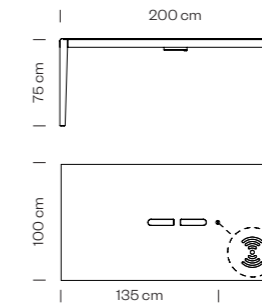

617 AB

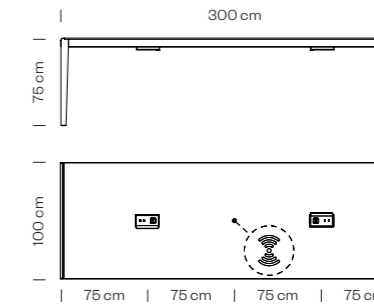

617 BC

